

Turnkey Energy Solutions

for stationary on-grid and off-grid applications



Motive Power Systems

Reserve Power Systems

Special Power Systems

Service

Your benefits with HOPPECKE Turnkey Energy Solutions

- **Highest project flexibility** - variable models for different energy supply systems
- **Maximum energy efficiency** - by use of high quality components
- **One-stop solutions** - consulting, planning, implementation and service from one source
- **Best environmental compatibility** - reduced CO₂ emissions by use of environmentally friendly electricity generators

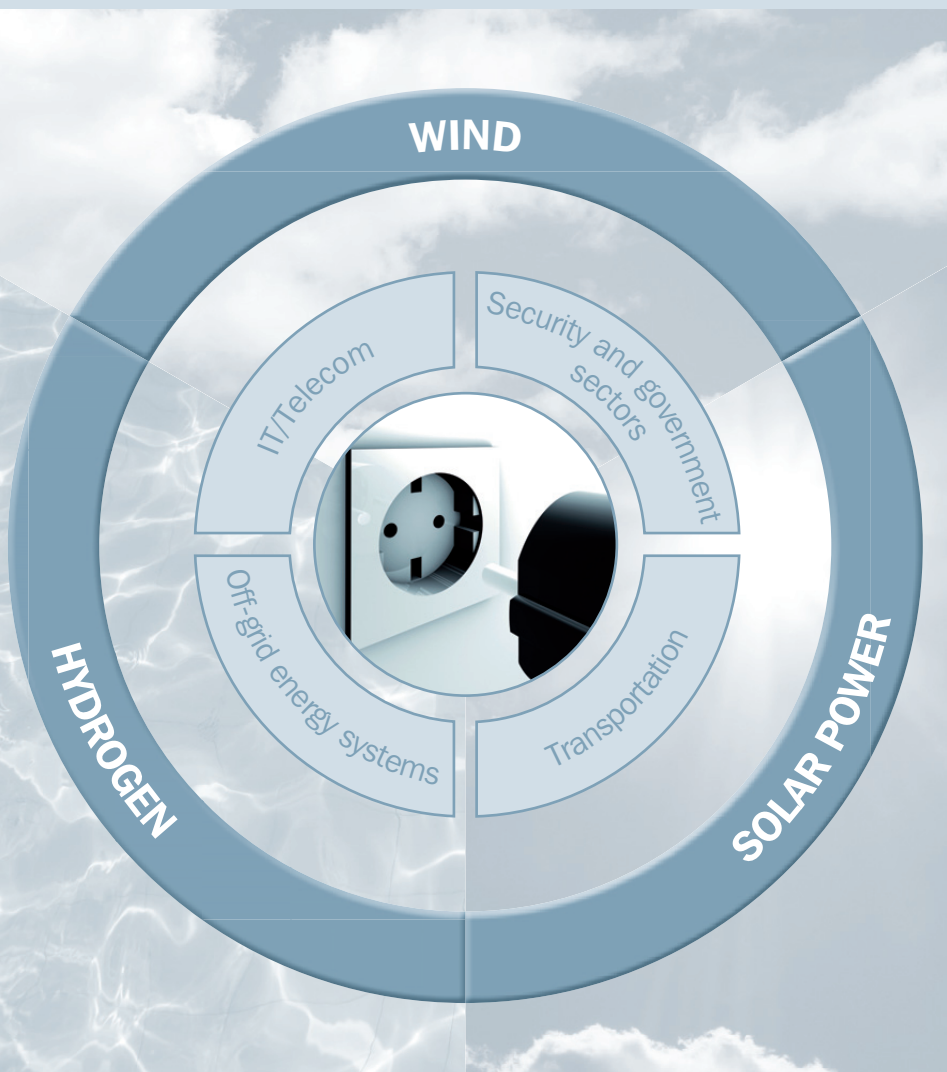

Typical applications of HOPPECKE Turnkey Energy Solutions

- **IT/Telecom**
BTS (base transceiver stations) for 3G and 4G wireless
- **Security and government sectors**
Tetra network
Surveillance/security systems
- **Transportation**
Signals/Signs
Flight control systems
- **Off-grid energy systems**
Power supply for health care facilities, weather and research stations



HOPPECKE

POWER FROM INNOVATION

The power supply of tomorrow

Hybrid power stations for stationary energy applications

Globalisation and its effects are leading to a continuous increase in the global demand for energy. Even continents, countries and locations with inadequate or non-existent electrical grid coverage are not being spared from this trend. The latest generation of hybrid off-grid energy systems offer an opportunity to provide an adequate electricity supply for locations across the world.

HOPPECKE offers you compact turnkey energy systems that are suitable both for grid-connected and stand-alone electrical energy supplies. This electricity supply concept is based on the utilisation of renewable energies such as solar, wind or hydrogen. Energy storage forms a central component in these hybrid systems.

HOPPECKE batteries from the solar.power range are distinguished by their excellent cycle stability, long life span in partial state of charge operation, as well as significantly improved storage capabilities, and as such, provide the ideal basis for the intermediate storage of surplus energy. This can be utilised at night or during periods of poor weather when residual energy sources cannot provide sufficient power.

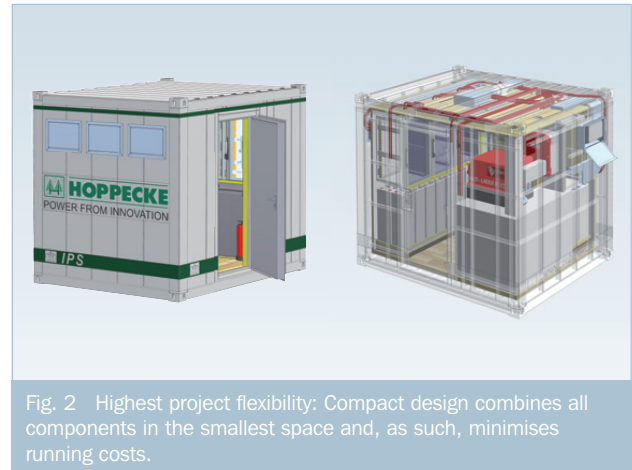

Fig. 2 Highest project flexibility: Compact design combines all components in the smallest space and, as such, minimises running costs.

Energy Container represents one possible realisation of this concept. All necessary components for energy storage, distribution and control are securely and compactly accommodated in this complete system. Depending on the model, the system also includes additional components, e.g. fuel cells, diesel generators or electrical equipment for the individual customer application – everything under one roof!

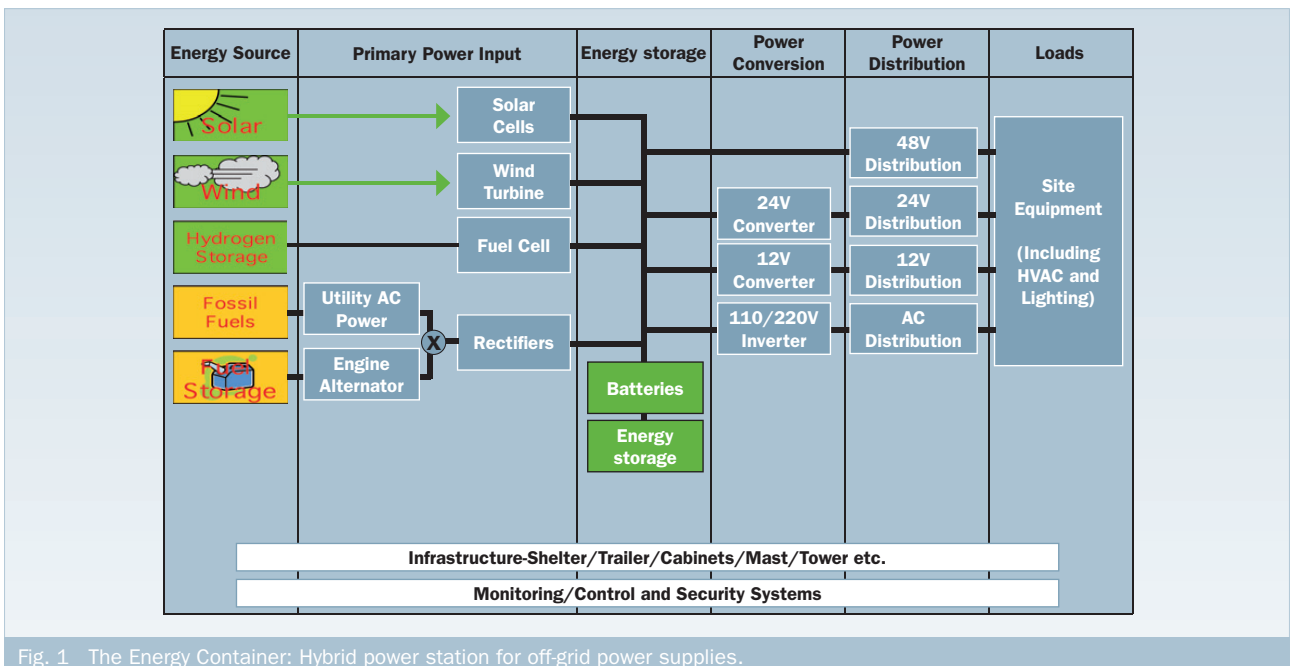

Fig. 1 The Energy Container: Hybrid power station for off-grid power supplies.

Operational characteristics of DC Cycling

As shown by the graph, the concept behind DC cycling is to allow the generator to operate at its peak efficiency and to shut off during low load demand and let the batteries power the load. This saves fuel and engine maintenance. Also shown is the DC generator's fuel reduction as the load decreases due to the variable speed feature of the DC generator. Allowing the engine speed to change and operate at near its most efficient power points also reduces the fuel consumption rate. The power output of a DC generator can be regulated so we can operate closer to the ideal engine power curve. This saves fuel because we can make use of smaller engines displacements. In the chart we show the DC generator operating at 80% of its rated power.

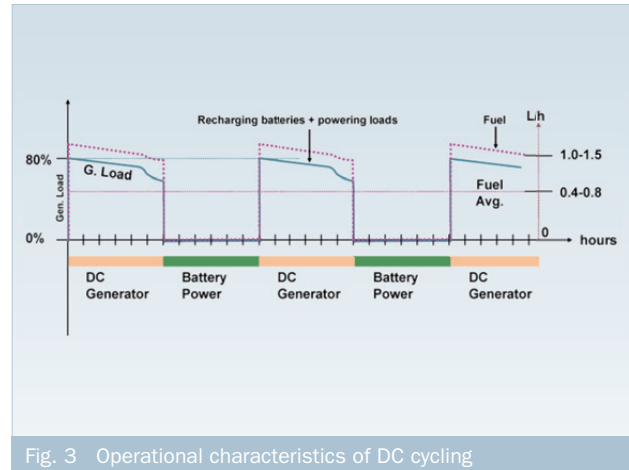

Fig. 3 Operational characteristics of DC cycling

Components	Possible variants for BTS stations		
	Back-up – Solution with battery storage	Off-grid solution (I)	Off-grid solution (II)
Consumer load	DC/AC	DC/AC	DC/AC
On-grid	x	–	–
Off-grid	–	x	x
PV	–	–	x
Wind power	–	–	(x)
Back-up energy	Diesel generator/fuel cells	Diesel generator/fuel cells	Diesel generator/fuel cells
Battery	Lead/Li-ion	Lead/Li-ion	Lead/Li-ion
Housing	Use of available space/containers	Containers	Containers

We offer more than just high quality batteries

■ Analysis and engineering

System planning, taking both the energy requirements of the customer application and the local conditions into account (generated from wind and/or solar energy).

■ Energy management

Operational management for best energy output and the greatest life span of all components.

■ Power conversion

Depending on the customer application, the electrical energy is provided in DC or AC voltage.

■ Power distribution

The project scope includes the complete energy distribution. No subsequent installation works are required.

■ Online monitoring

Remote monitoring and control of critical system parameters (via Internet/GSM/GPRS).

EVERYTHING FROM ONE SOURCE!



Motive Power Systems



Reserve Power Systems



Special Power Systems



Service



HOPPECKE subsidiaries and factories - European sales and service network

Industrial batteries - Complete energy systems - Full Service

- VRLA batteries in Gel or AGM Types
- VLA batteries
- Single cell or block design
- Battery accessoires
- Battery management systems and software
- Batterie/charger servicing
- Battery recycling
- Applications engineering and technology
- Battery room design
- Technical training and seminars
- Leasing
- Power by the hour

Your partner for sustainable energy solutions!

Further information on www.hoppecke.com

HOPPECKE Batterien GmbH & Co. KG

P.O. Box 1140 · D-59914 Brilon
Bontkirchener Straße 1 · D-59929 Brilon-Hoppecke

Phone: + 49 (0) 29 63 61-3 74

Fax: + 49 (0) 29 63 61-2 70

Email: info@hoppecke.com

Internet: www.hoppecke.com



POWER FROM INNOVATION